



CATALOG#: _____
 PROJECT: _____
 TYPE: _____

Series LPS

Midsize Electrical Inverter

Midsize-electrical inverter systems for powering 375 up to 600 watts of incandescent, fluorescent, induction or LED lighting loads. Pulse width modulated (PWM) output design provides clean, 60 Hz sinusoidal emergency power to loads.

Unlike a ballast fluorescent emergency pack, the LPS provides power to the input side of the fixture, (including the ballast) eliminating any chance of incompatibility. The LPS Series is designed for surface mounting. All LPS systems will provide emergency power output for a minimum of 90-minutes.

HOUSING

Heavy duty steel cabinet is finished in white baked-on powder paint providing scratch and corrosion resistance. Optional special color paint (-SP) finishes are available. Consult factory.

MOUNTING

Surface Mount: Surface mount models are designed for mounting to walls by means of keyhole slots provided in the back of the unit housing.

WIRING

Connection to an unswitched AC unit circuit is required by the NEC. Wiring access is provided for by conduit knockouts in the unit housing

WARRANTY LISTING

- Unit (excluding lamps): Full coverage against defects in materials and workmanship for 3 years from date of shipment
- Battery: 3 years full warranty plus an additional 7 years of pro-rata coverage
- All models are UL924 Listed and meet NFPA 101 Life Safety Code, NEC, OSHA, Local and State Codes
- UL Listed for damp locations (20° - 30°C)

STANDARD



TRUE
SINUSOIDAL
OUTPUT POWER

LPS-375 MODEL



LPS-600 MODEL



DIMENSIONS

LPS-375:18"L x 16.625"H x 8.25"W

LPS-600:18"L x 25.25"H x 8.25"W

FEATURES & BENEFITS

- For powering incandescent, fluorescent, induction and LED fixtures (consult factory for compatibility for other lamp types)
- Sinusoidal output eliminates compatibility problems
- Universal 120/277VAC, 60Hz input/output
- Unit capacities up to 600 watts
- "Soft Start" design reduces fixture inrush current
- Unit may be installed up to 1000 ft from controlled fixture(s)
- Lumen output from fixture is 100% of nominal
- Unique design eliminates compatibility problems with LED drivers as well as fluorescent and induction ballasts
- Compatible with dimming ballasts
- Normally-ON and/or Normally-OFF load output
- Provisions for local switching capability - Always on during emergency conditions regardless of local switch position
- Emergency fixtures can be ON, OFF or SWITCHED
- Solid-state, line latched low voltage disconnect provides protection against battery deep discharge
- Long life, maintenance-free lead-calcium battery
- Momentary test switch
- AC-ON, Charge-ON and Inverter-ON LED indicators



CATALOG#: _____
 PROJECT: _____
 TYPE: _____

Series LPS

Midsize Electrical Inverter

ELECTRICAL SPECIFICATIONS

Input

- Input Voltages: Universal 120 or 277VAC, 60Hz (user selectable with (2) wire jumpers provided)
- Input Frequencies: 60Hz \pm 2%
- Input Surge Protection: Meets UL924
- Input Protection: Provided by Service Panel rated at 20 amps maximum

Output:

- Output Voltages: (60 Hz) 120 or 277VAC
- Efficiency Rating: 98% at full rated load (line)
- Waveform: Sinusoidal (digitally controlled)
- Static Voltage: \pm 5% during battery discharge. 0-100% linear load
- Output Frequencies: 60Hz \pm 0.3Hz during emergency cycle
- Output Distortion: Less than 3% THD (linear load)
- Transfer Time: Less than 1.0 second
- Load Power Factor Range: 0.88 Lead to 0.88 Lag
- Minimum Loading: 0% of rated system capacity
- Output Protection: Circuit breaker

LOAD COMPATIBILITY

LPS models clean, sinusoidal AC output will operate incandescent lamps as well as all common fluorescent, induction and LED lamp types. Consult factory for compatibility with all other lamp types.

Lighting loads are driven at 100% output for the entire emergency power cycle. This outstanding feature translates into greater occupant egress vision and safety.

IMPROVED AESTHETICS

The LPS system's sinusoidal AC output design eliminates voltage drop and proximity concerns. This allows added flexibility in installation location as LPS units can be installed hundreds of feet from the units they power. This means LPS units can be located conveniently out of sight in closets or utility rooms without interrupting architectural aesthetics.

In lighting application, no special or additional emergency fixtures are necessary. Simply designate and connect existing lighting fixtures, either interior or exterior, to the LPS unit for emergency operation eliminating the need for exposed, stand-alone emergency luminaires.

GENERAL SPECIFICATIONS

Model Number	Input/Output Voltage	Capacity for 1.5 Hrs. (Watts/VA)	System Weight		System Efficiency (Full Load)	# of Batteries	Battery Voltage (VDC)	Battery Current (Amps)	AC Input Current (Max)		Thermal Output (BTUs)	
			Lbs.	Kg.					120VAC	277VAC	On-Line	Emergency
LPS-275	120/277 VAC	375/375	113	51.3	98%	5	60	7.3	3.43	1.49	11	205
LPS-600	120/277VAC	600/600	172	78.1	98%	8	96	7.1	5.50	2.38	15	275

SYSTEM OPTIONS (1) (2)

Add Suffix	Description
-OCB1	One output breaker
-OCB2	Two output breakers
-ICB	Input breaker
-SP	Special Housing Color (specify)
-AO	Adjustable Output / Dimmer Bypass (3)
-4C	Four Output Circuit Switching (3)
-SDT	Self-Testing / Self Diagnostics (3)

Note:
 (1) Other options available. Consult factory.
 (2) Some options may impact product UL Listing. Consult factory.
 (3) For more information, separate specification sheets are available on the -AO, -4C and -SDT options. Consult factory.
 (4) The OCB option cannot be ordered with the 4AO or 4C option in the same unit.

DRAWINGS & IMAGES

LPS-375

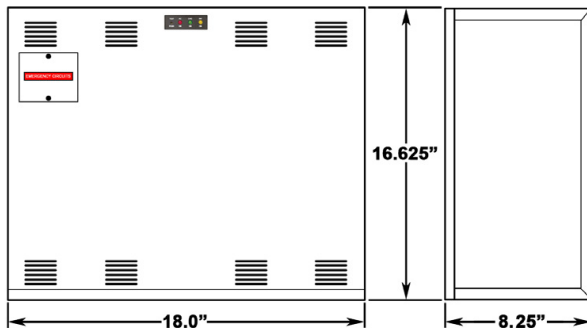

LPS-600

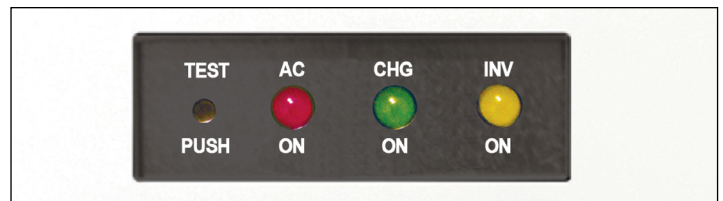
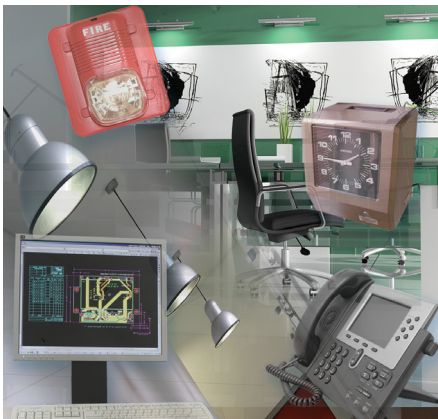
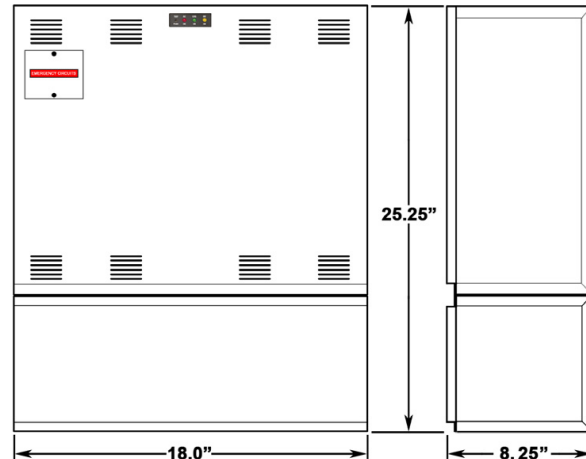

SYSTEM MONITORING PANEL

All LPS systems provide a monitoring panel on the front of the unit to show operating status at all times. The panel provides a switch for user initiated system tests and a 3-LED array that provides an intuitive visual indication of unit readiness.

We reserve the right to change design, materials, LEDs and finish in any way that will not alter installed appearance or reduce function and performance.



CATALOG#: _____
PROJECT: _____
TYPE: _____

Series LPS

Midsize Electrical Inverter

OPERATION

Upon failure of the normal utility power the LPS unit is automatically turned on by a solid state switching circuit and provides a minimum of 90 minutes of emergency power to the connected load. Lumen output will be maintained at 100% of the lamp's rating throughout the entire duration.

A solid state low voltage disconnect circuit is used to protect the battery from being severely damaged by a deep discharge. When normal utility power is restored, the unit switches the load back to normal utility operation and the fully automatic, temperature compensated, dual mode charger begins to restore the battery bringing it to full charge within UL 924 specified parameters. A brownout sensing circuit insures proper operation during "low line" conditions.

BATTERY

Battery: Sealed Lead Calcium (10 year life)

Battery Voltage: 60VDC for LPS-375 model and 96VDC for LPS 600 model.

Runtime: 90 minutes standard - based on battery performance at 77°F (25°C) Other runtimes available. Consult factory.

Battery Protection: Low Voltage Battery Disconnect protects the battery from being severely damaged by deep discharge

CHARGER

Charger Type: Fully automatic, temperature compensated, dual-mode charger

Power Consumption: (Charger only) 37W maximum (2.5W in standby) for LPS-375 model

56W maximum (5W in standby) for LPS-600 model

Recharge Duty Cycle: Meets UL924 requirements

Battery Circuit Breaker: Also used as battery isolater

Controls: Monetary test switch, AC-On, Charge-On and Inverter-On LED indicator lights

Safety Circuitry: AC Lockout prevents battery discharge prior to initial power-up.

Brownout Protection automatically switches the unit to emergency mode when utility voltage is significantly reduced.

ENVIRONMENTAL

High Altitude Operation: Maximum operating temperature drops 1 degree C per 300 meters (2 degrees F per 1000 feet) above sea level.

Operating Temperature Range: 68°F to 86°F (20°C to 30°C)

NOTE: Optimum system performance between 20°C (68°F) and 30°C (86°F); temperatures outside of this range will affect battery performance and life

Relative Humidity: 95% non-condensing

LPS SYSTEM ADVANTAGES

Compared to traditional discrete emergency lighting units, the LPS Series provides emergency illumination from a single power source resulting in lower maintenance overhead and routine testing expenses. LPS units lower installation costs by powering existing lighting fixtures during emergencies. And because connected fixtures are driven at full brilliancy, they provide far more superior egress lighting and deliver improved occupant safety.

WIRING DIAGRAMS

NORMALLY ON LOADS

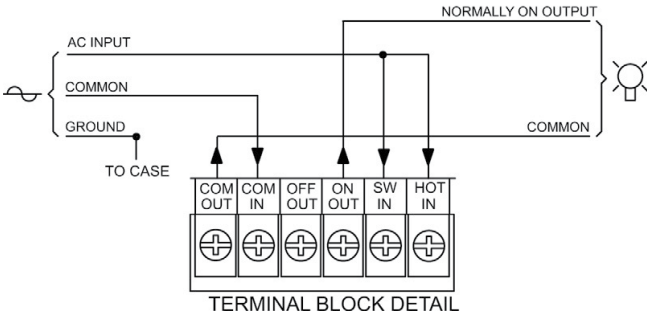

NORMALLY OFF LOADS

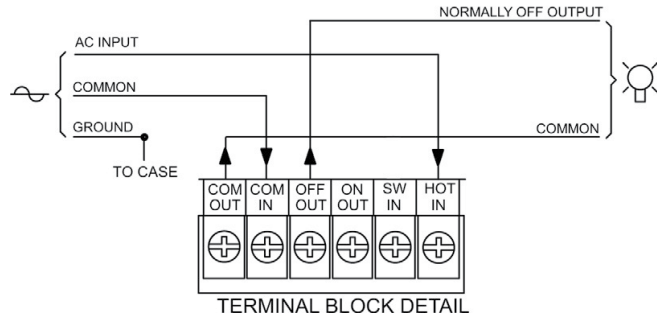

NORMALLY ON & OFF LOADS

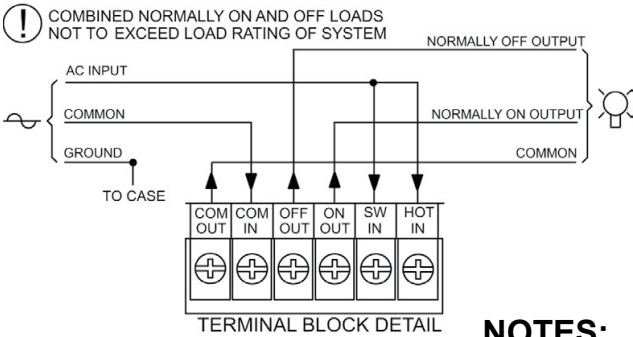

SWITCHED LOADS

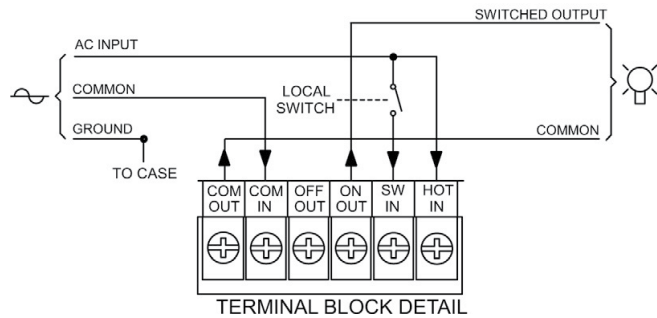

NOTES:

- ⚡ INPUT SUPPLY FROM UNSWITCHED UTILITY RATED 20 AMPS MAXIMUM.
- 💡 OUTPUT(S) TO LIGHTING LOADS

VOLTAGE SELECTION DETAIL

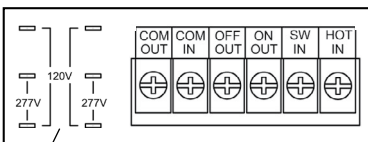

NOTE:
 Factory terminated jumper wires
 are provided with LPS Systems for
 making user selected input/output
 voltage connections.



CATALOG#: _____
PROJECT: _____
TYPE: _____

Series LPS

Midsize Electrical Inverter

SUGGESTED SPECIFICATIONS

An inverter system with sinusoidal output shall be supplied capable of powering any combination of lighting fixtures, including incandescent, fluorescent, induction and/or LED light sources without compatibility problems.

The system shall transfer in less than 1.0 second to reliably back up lighting fixtures without loss of illumination and operate any and all connected lighting fixtures at full lumen output during the complete 90-minute discharge cycle.

The input voltage shall be the same as the output voltage and shall be single phase 120/277 volts, 60Hz. Output capacity will be (375W/375VA) (600W/600VA) for a minimum duration of 90-minutes.

The design shall be a standby, off-line inverter with an on-line efficiency of 98%; on-line double conversion UPS systems shall not be considered acceptable alternatives. LPS System output shall be a PWM generated sine wave with less than 3% total harmonic distortion with "Soft Start" design reduces fixture inrush current. The system shall also provide short circuit and overload protection as standard.

An intuitive three LED display shall provide system operational information at a glance and alert user to any malfunction in system performance. Authorized maintenance personnel shall have access to the system's controls while being protected from any live exposed connections.

Protective devices shall include AC Line fuses, DC input breaker and a DC input fuse. The entire LPS system, including batteries, shall be incorporated into compact cabinetry which shall have provisions for surface mounting.

System shall be capable of providing up to 4 switch bypass circuits, adjustable output or 2.5 to 10 volt dimmer bypass and self-test/self-diagnostics, were necessary.

System shall utilize a sealed lead calcium battery with a 10 year design life. The charger shall be temperature compensated, dual mode type, and recharge the batteries as per UL924 guidelines. Entire system shall be tested, approved, and labeled to UL924 Emergency Lighting and Power Systems standards.